

SECTION/OPERATION

24

ROTOR BLADES

<u>COMPONENT</u>	<u>PROCEDURE</u>	<u>PRINT #</u>	<u>TEMPLATE</u>
ROTOR BLADES (E20-2000)	Construct	E20-2000	

NOTES

FLIGHT TRAINING: It is recommended at this time to attend flight training to review the rigging of the rotor system and controls.

ROTORWAY

TOOLS REQUIRED FOR OPERATION 24:

"C" clamps	
Dial calipers	
Drill bits of the following sizes:	3/32"
	1/8"
	1/4"
	5/16"
	#32
	#47
Grinder	
Hacksaw	
Level	
Protractor level	
Ratchet with sockets of the following sizes:	3/8"
	7/16"
	1/2"
	9/16"
	7/8"
Router	
Ruler	
Sand paper	
Screwdriver	
Spring clamps	
Straight edge	
Torque wrench	
Wrenches of the following sizes:	3/8"
	7/16"
	1/2"
	9/16"
	7/8"

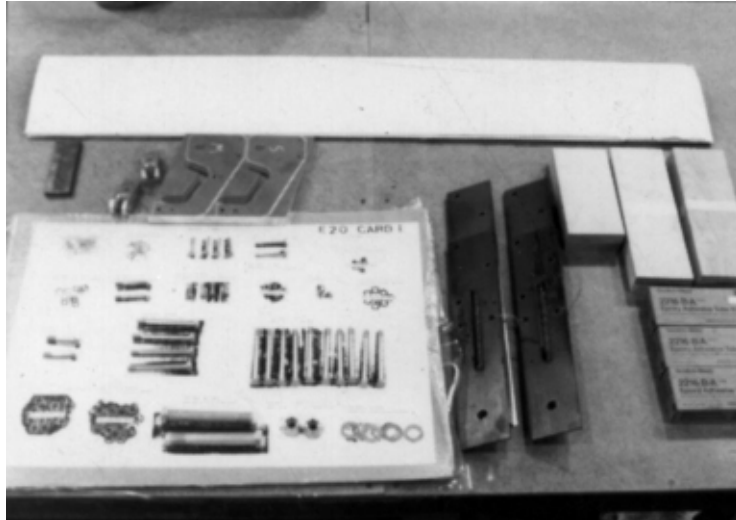

Photo #1

Use Print E20-2000 when constructing this assembly. Parts as received from RotorWay International.

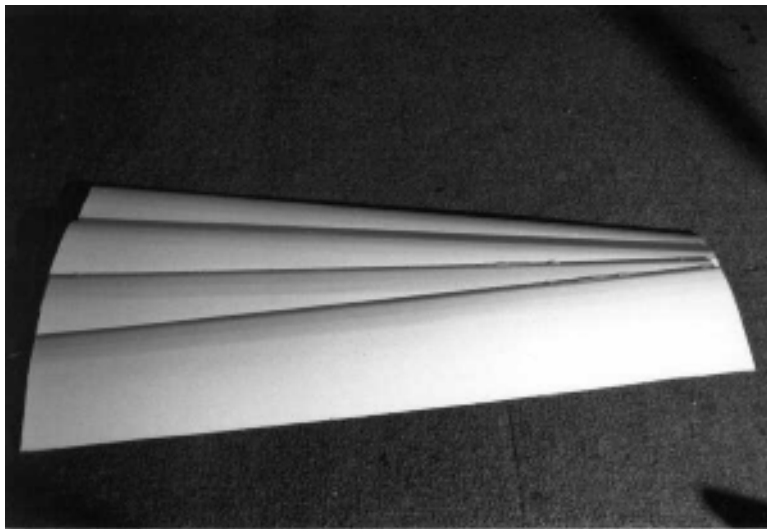

Photo #2

Doublers as received.

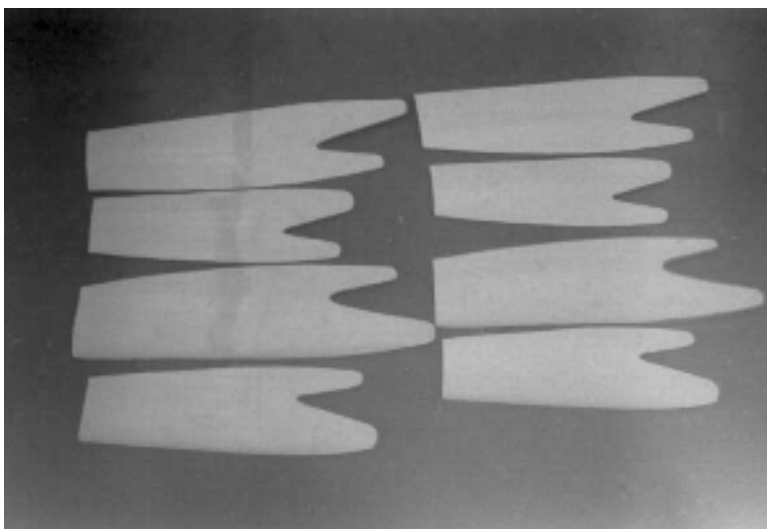

Photo #3

Cut out the doublers to the scribe lines.

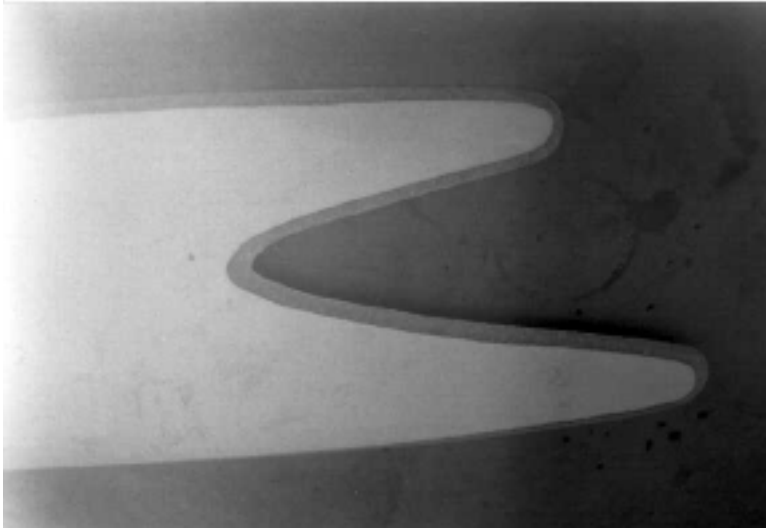

Photo #4

Chamfer the edges of the doubler except along the front edge where the wood filler block will go. Use 220 grit sandpaper and sand both sides of the fiberglass doublers.

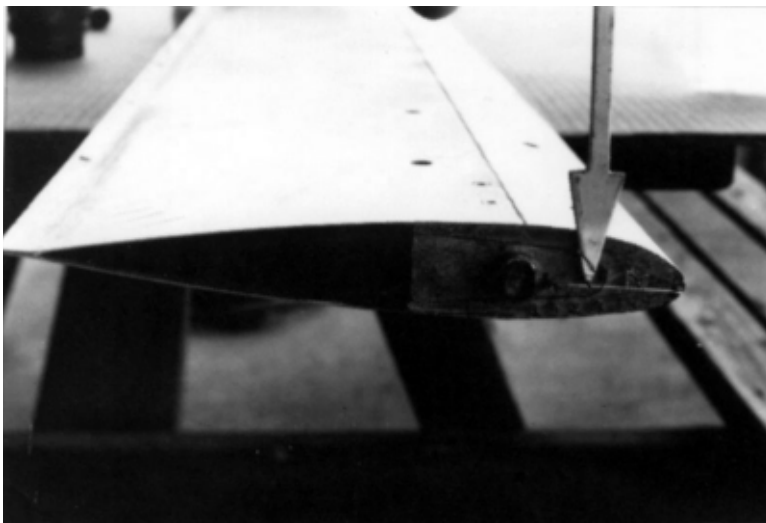

Photo #5

Make a permanent mark on the chord line on the end of the blade.

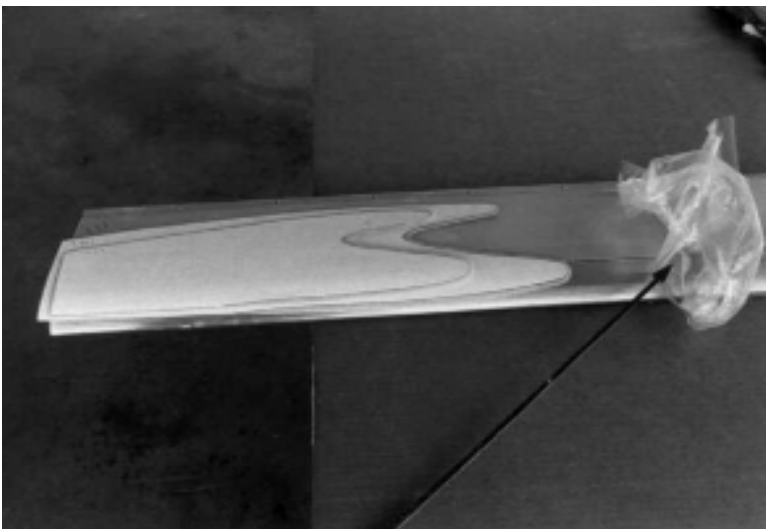

Photo #6

Remove the plastic cover on the root end of the blades far enough to fit and glue the fiberglass doublers.

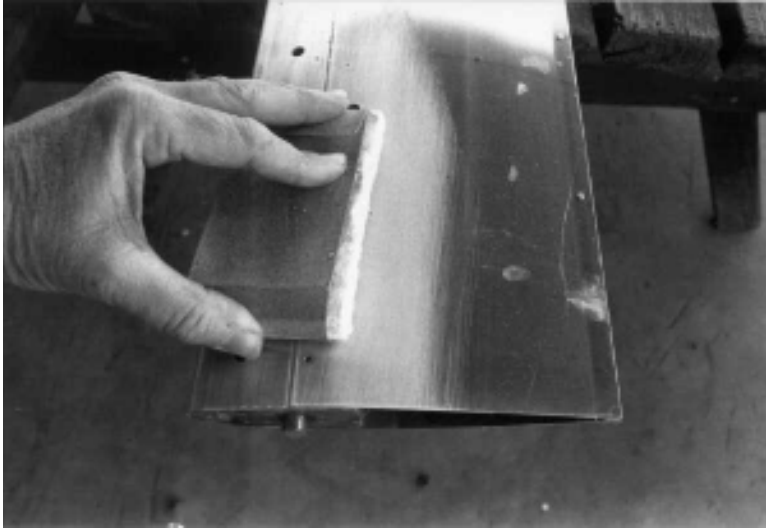

Photo #7

Using 220 grit sandpaper, sand lengthwise on both sides of both blades to a satin finish.

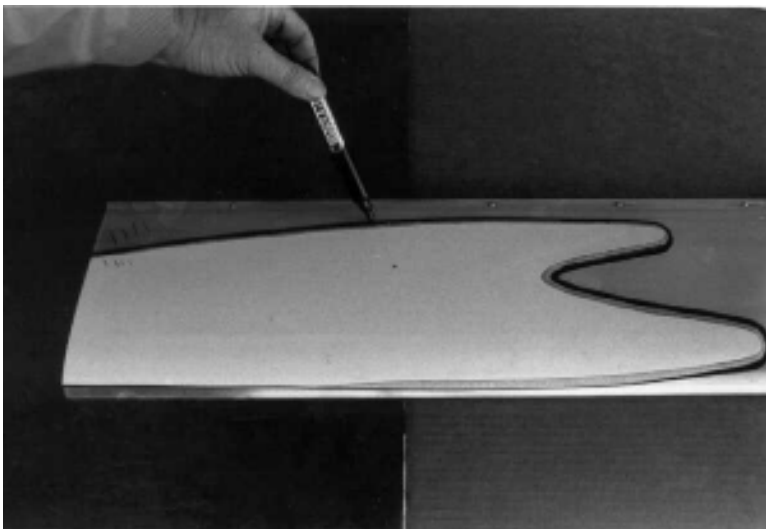

Photo #8

Place the large doubler on one side of the blade where it fits the best. Mark the outline of the doubler with a felt pen.

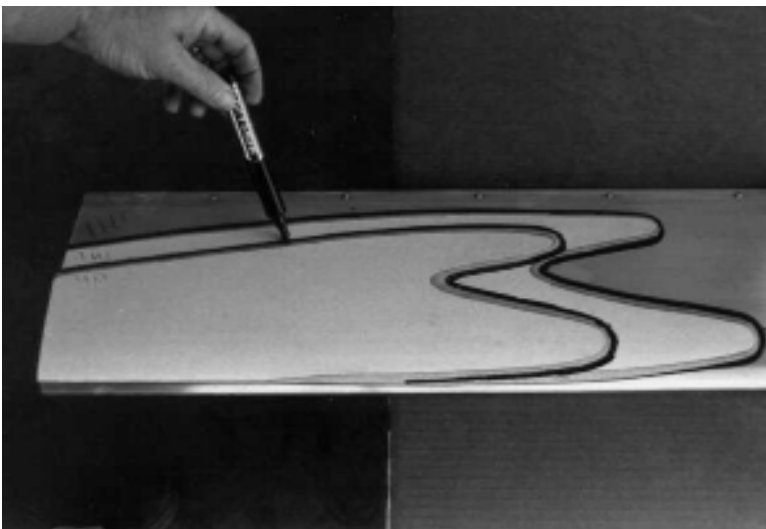

Photo #9

Place the small doubler on the large doubler where it fits the best. Mark the outline of the doubler with a felt pen.

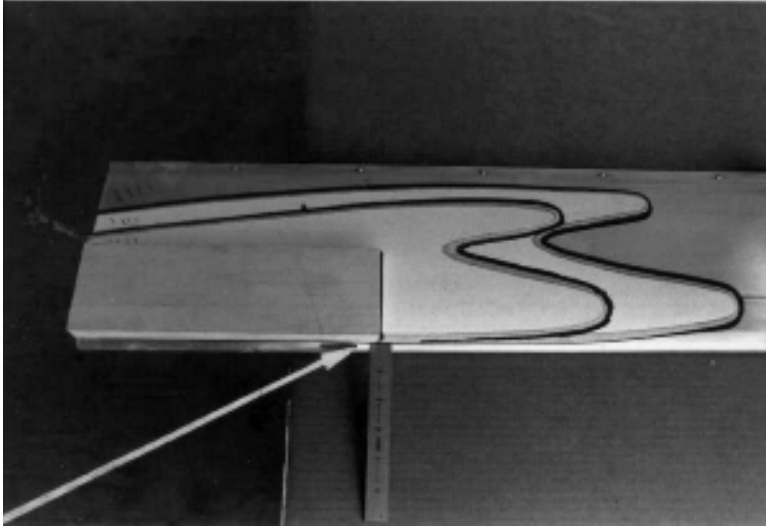

Photo #10

Place the wooden filler block on the small doubler. The front edge of the wooden filler block should be parallel and 5/16" from the leading edge.

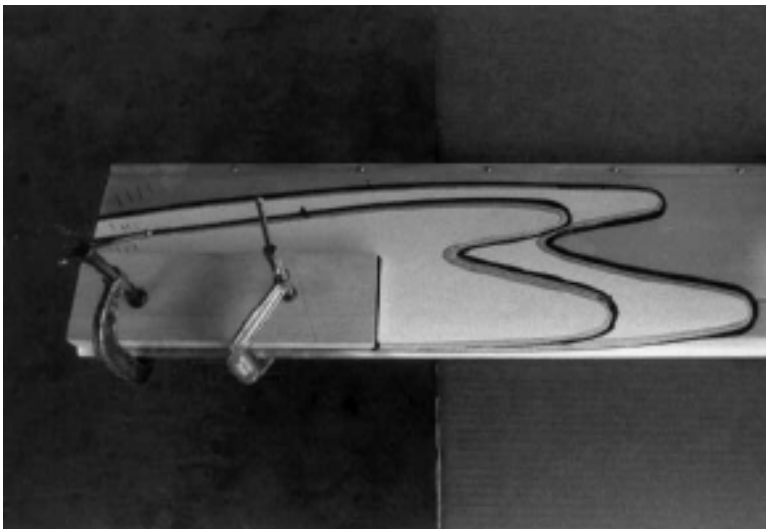

Photo #11

Clamp the wooden filler block and the two fiberglass doublers to the blade.

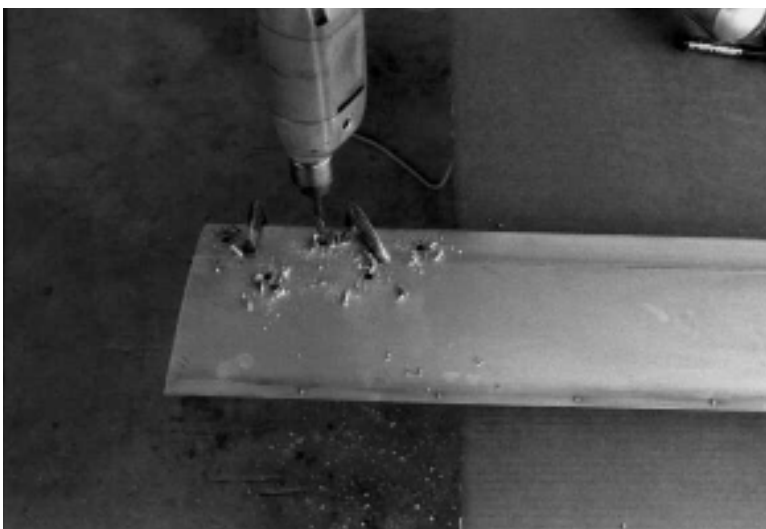

Photo #12

Turn the blade over. Using the holes in the blade as a drill template, drill the holes in the wooden filler block and fiberglass doublers. Mark the parts and remove them. Detail them for gluing. Repeat this procedure on the other side of the blade, and on the other blade.

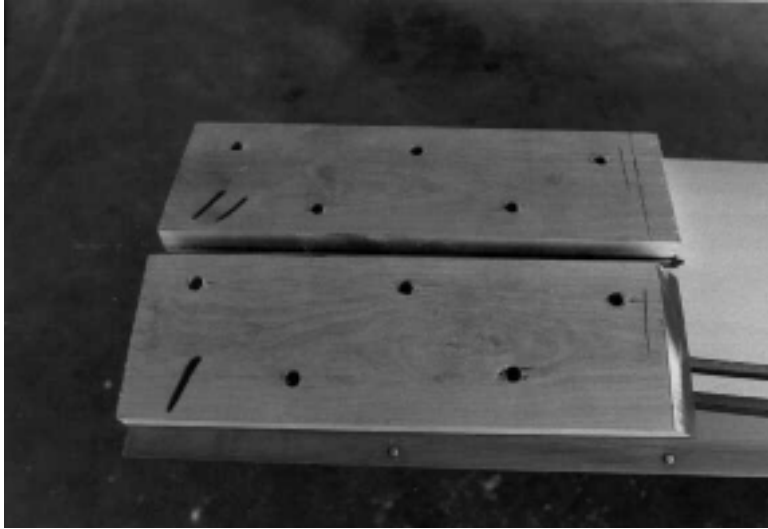

Photo #13

Draw a line 3/4" from the edge of the hole farthest from the root end of the blade. Taper the block from this line to the end of the block.

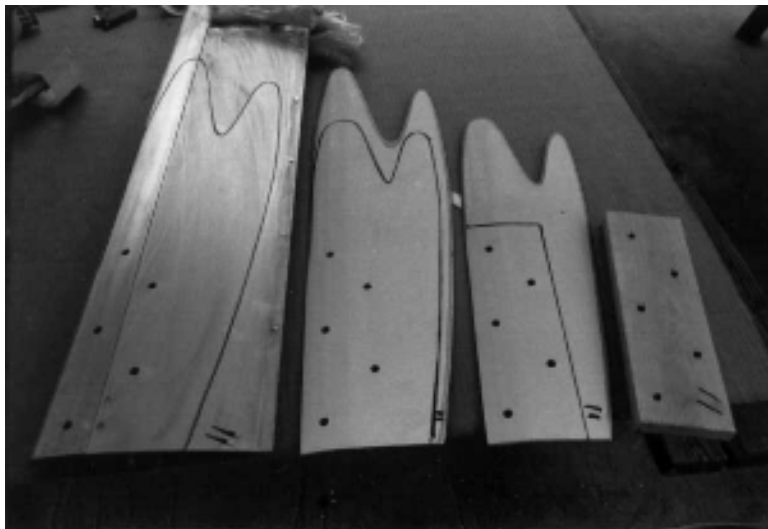

Photo #14

Clean the fiberglass doublers and the wooden filler block with acetone and place them on the blade. Outline the parts with a felt tip pen. Lightly clean the blades also with acetone.



Photo #15

Items needed to glue the fiberglass doublers and the wood filler blocks to the rotor blades.

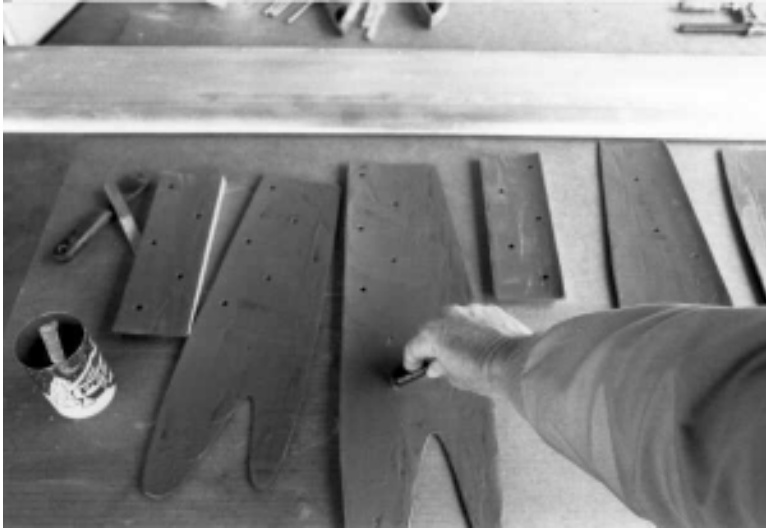

Photo #16

Mix the 3M structural adhesive in a small container for best results. Place the fiberglass doublers and wooden filler block upside down on the work table and apply the 3M structural adhesive to the parts. Apply with a strip of rubber for better control of the adhesive.

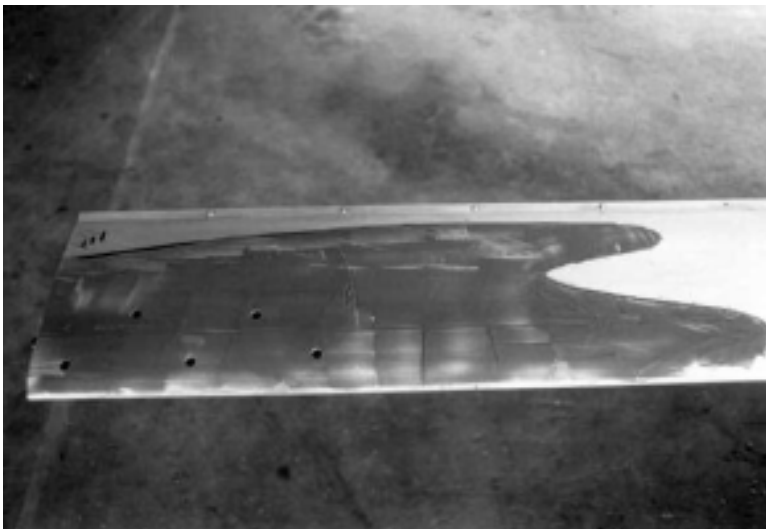

Photo #17

Apply the 3M structural adhesive to the outlined area of the blade.

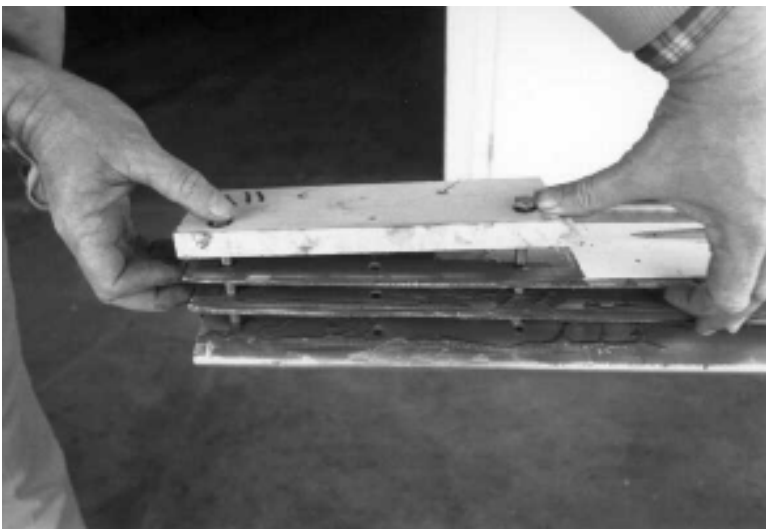

Photo #18

Align the holes in the blade and the fiberglass doublers. Place the other doubler so the holes align and apply the 3M structural adhesive to the outlined area on the top of the small doubler. Align the holes in the wooden filler block. Grease two long 5/16" bolts and install them in the two holes at each end of the wooden filler block.

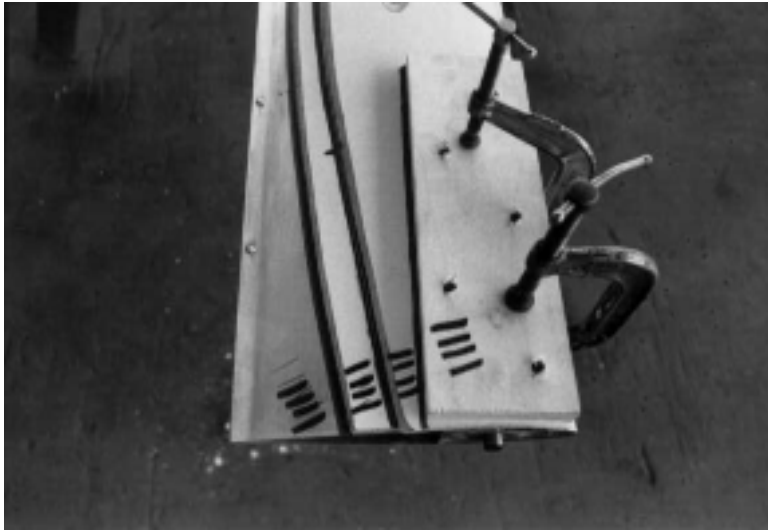

Photo #19

Repeat this procedure on the other side of the blade.

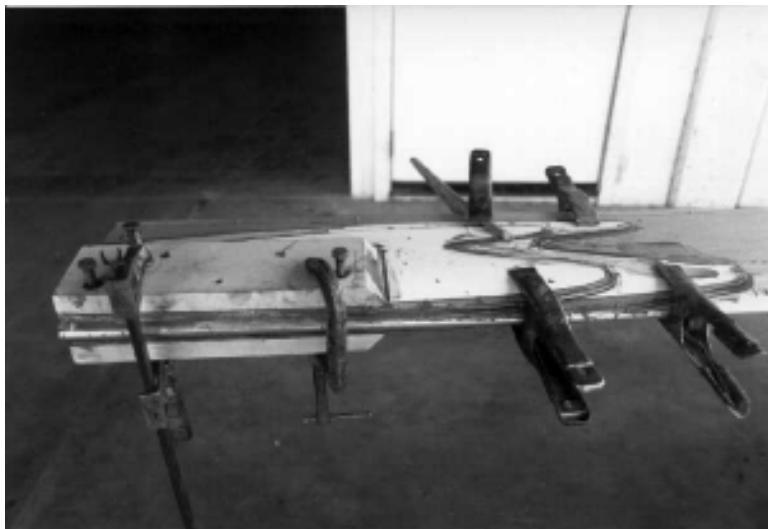

Photo #20

Use two C clamps and as many spring clamps as necessary to hold down the fiberglass doubler.

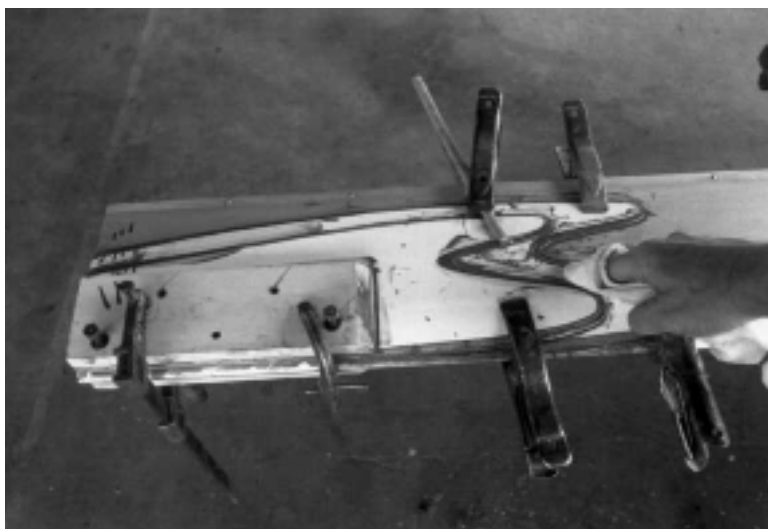

Photo #21

Use a clean rag to wipe off the excess glue from the fiberglass doubler, wood filler block, and blade.

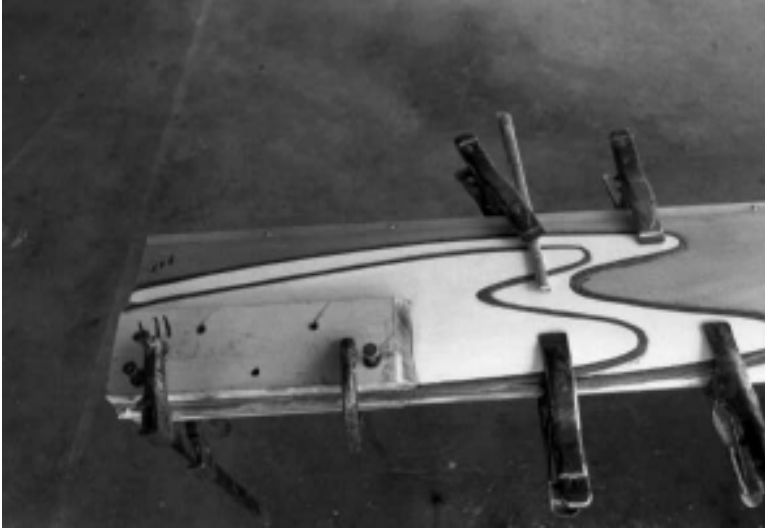

Photo #22

This is the way it should look after wiping off the excess glue.

Note: When using acetone to clean the doublers, use only enough to dampen the rag. Acetone will affect the glue.

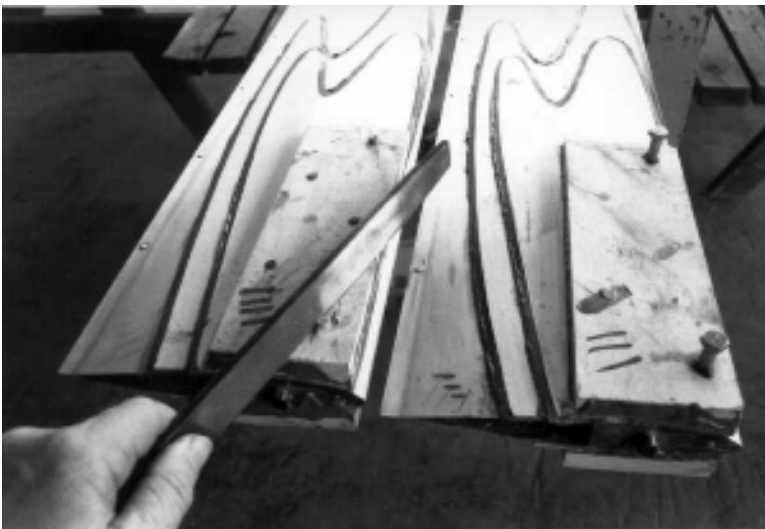

Photo #23

After the glue has cured for 10 to 12 hours, remove the 5/16" bolts. To do this, first remove any glue on the end of the bolts, then place the wood filler block on a table so that the bolt is close to the edge of the table. With a hammer and punch, drive out the bolts.

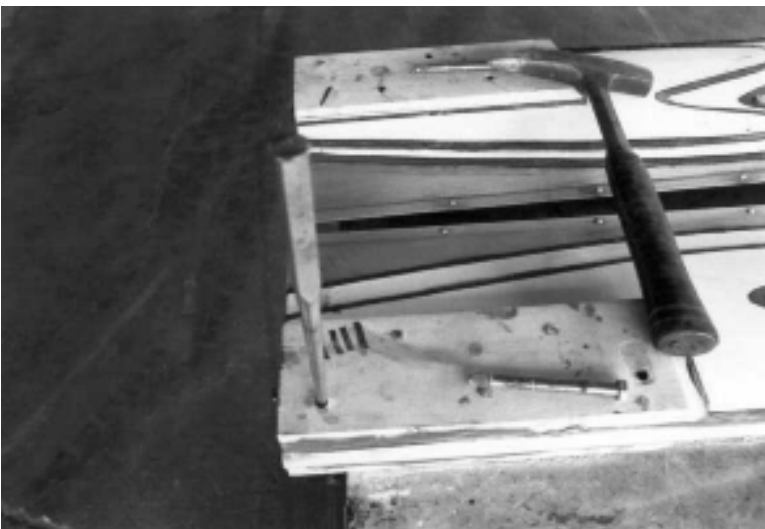

Photo #24

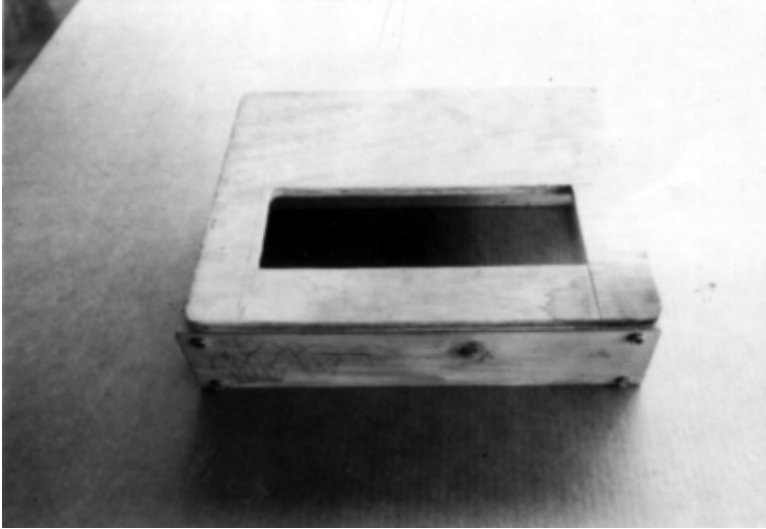

Photo #25

Make a wooden router fixture to fit on the root end of the blade. This fixture will be used to cut the surface of the wood filler blocks to the correct dimension.



Photo #26

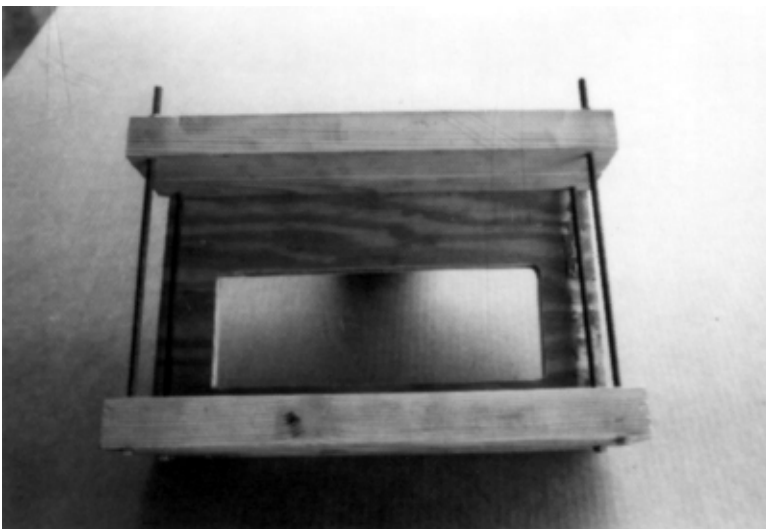

Photo #27



Photo #28

To build the router fixture, take a straight 2"x 4", approximately 30" long, and cut a groove in the middle of the 3-5/8" side along the complete length. This can be done by using a router bit in a drill press. Clamp a guide board on the table and hold the 2"x 4" against the guide board when routing. This will ensure a straight groove.

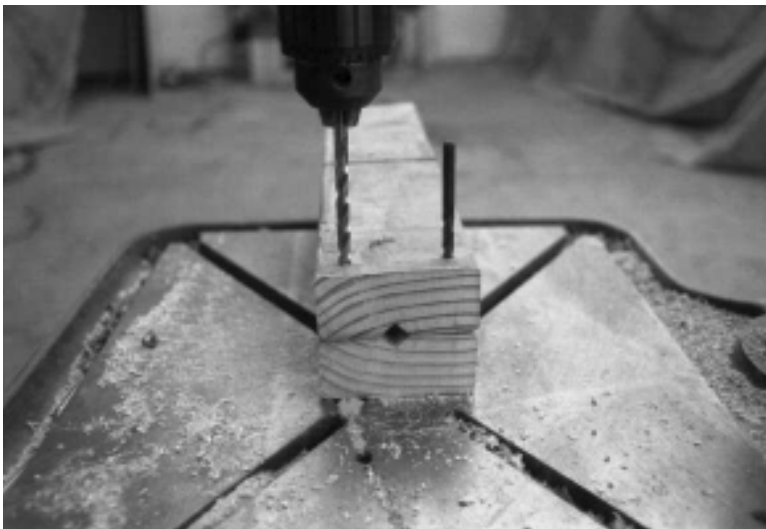

Photo #29

Cut the 2"x 4" in half, clamp the two halves together and drill a 1/4" hole in each corner. Use 4 pieces of 1/4" all thread rod with nuts and washers (these are not supplied with the kit, but can be purchased from a local hardware store).



Photo #30

Clamp the 2"x 4" on the blades so that the leading and trailing edges of the blades are in the grooves.

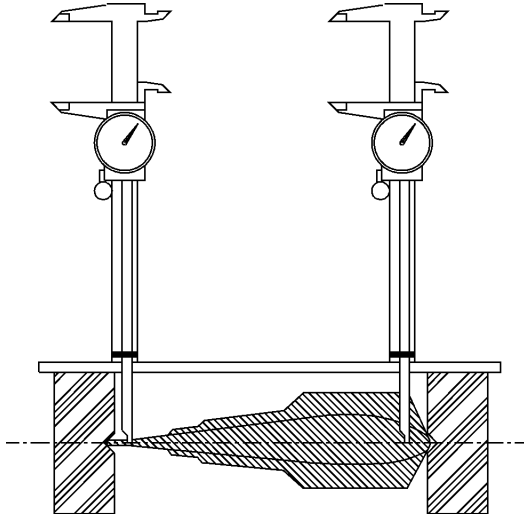

Photo #31

Place a straight edge across the 2"x 4"s. Measure the distance from the straight edge to the chord line at the leading and trailing edges of the blade. The distances must be the same. If they are not, add tape to the 2"x 4"s under the straight edge to make them the same. This will ensure that the routed surface and the chord line will be parallel. Do this on each side of each blade before routing.

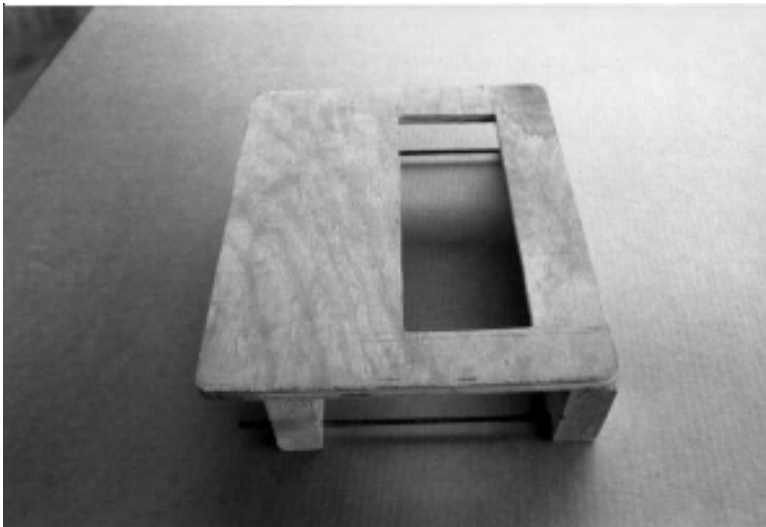

Photo #32

Cut a piece of plywood to cover the 2"x 4"s. Cut a hole in the plywood in the area that will be over the wood filer block. Use small nails or screws to hold the plywood in place when routing.

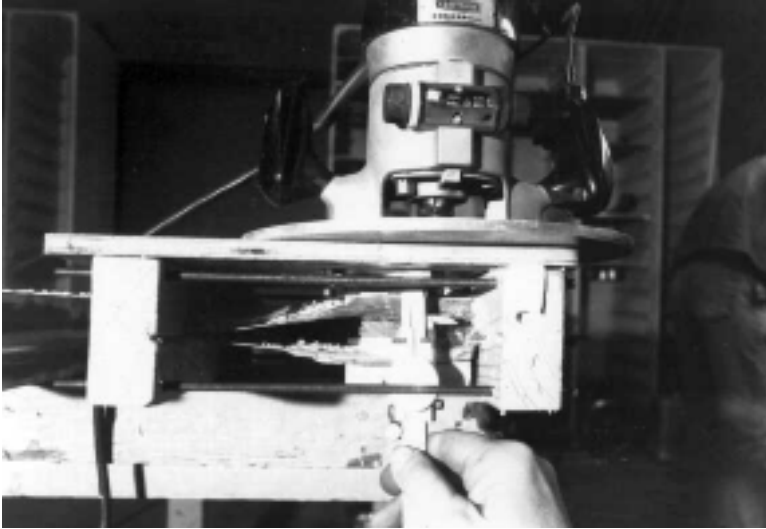

Photo # 33

Set the router bit so that when the wood filer block is cut, it will measure 1.125" (+.010 -.000) from the surface to the chord line. The block can be sanded to the exact thickness with a piece of sandpaper wrapped around a board.



Photo #34

Using a #2 pencil with normal pressure, cover the surface to be sanded.

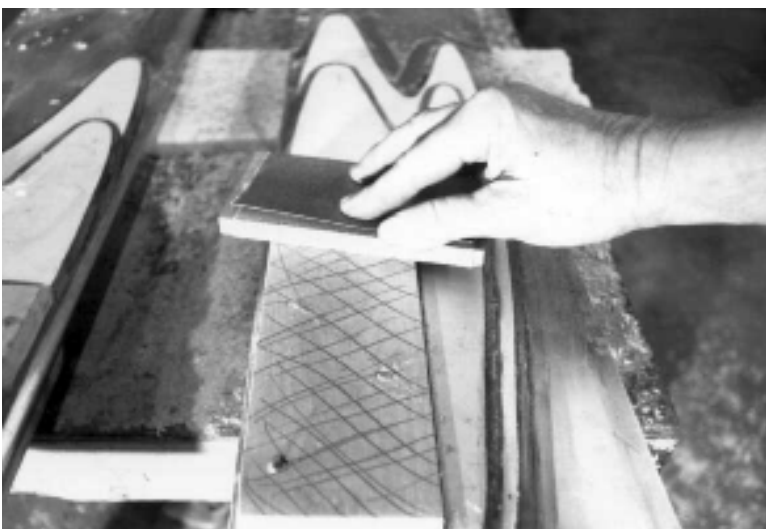

Photo #35

Wrap the sandpaper around a block of wood for even sanding.



Photo #36

Sand until all signs of the marks are gone. This method normally removes .002".



Photo #37

Three items to check after routing:

1. Overall thickness 2.250".
2. Chord line dead center.
3. Top and bottom wood surfaces and chord line are parallel.



Photo #38



Photo #39

Refer to drawing E20-2000. With a felt marker and straight edge, mark where trailing edge of blade is to be cut.



Photo #40



Photo #41

Use a hack saw to cut on the line.